

Stoßdämpfer sind hydraulische Geräte, die eine bewegte Last schnell und sicher zum Stillstand bringen – ohne Rückstoß oder Rücklauf.

Sie bewirken eine konstante, lineare Verzögerung bei der geringst möglichen Reaktionskraft in der kürzest möglichen Anhaltezeit.

- Kompakte und schwere Ausführungen
- Hohe Energie-Aufnahme
- Kleine Rückstellkräfte
- Lange Lebensdauer
- Erhöht die Produktivität
- Reduziert den Wartungsaufwand



Technische Daten

Bauart	Selbsteinstellend
Betriebstemperatur:	
MC9 bis MC 600	0 bis 65°
SC925	-12 bis 90°
MC33 bis MC64	-12 bis 70°

Software zur Auslegung auf separater CD: PDE2524TCUK-CD

Weitere Informationen finden Sie unter www.parker.com/euro_pneumatic

Baureihe MC 9 bis MC 600

Hub (mm)	Ø	Bestell-Nr.
5	M6 x 0,5	MC9M-1-B
5	M6 x 0,5	MC9M-2-B
5	M8 x 1	MC10ML-B
5	M8 x 1	MC10MH-B
6,6	M10 x 1	MC25ML
6,6	M10 x 1	MC25M
6,6	M10 x 1	MC25MH
10	M12 x 1	MC75M-1
10	M12 x 1	MC75M-2
10	M12 x 1	MC75M-3
12,5	M14 x 1,5	MC150M
12,5	M14 x 1,5	MC150MH
12,5	M14 x 1,5	MC150MH2
12,5	M20 x 1,5	MC225M
12,5	M20 x 1,5	MC225MH
12,5	M20 x 1,5	MC225MH2
25,4	M25 x 1,5	MC600M
25,4	M25 x 1,5	MC600MH
25,4	M25 x 1,5	MC600MH2

Baureihe SC 925

Hub (mm)	Ø	Bestell-Nr.
40	M25 x 1,5	SC925M-1
40	M25 x 1,5	SC925M-2
40	M25 x 1,5	SC925M-3

Zubehör

Anschlaghülse

Serie	Bestell-Nr.
MC 9 M	AH6
MC 10 M	AH8
MC 25 M	AH10
MC 75 M	AH12
MC 150 M	AH14
MC 225 M	AH20
MC 600M	AH25
SC 925 M	

Klemm-Flansch

Serie	Bestell-Nr.
MC 9 M	MB6
MC 10 M	MB8
MC 25 M	MB10
MC 75 M	MB12
MC 150 M	MB14
MC 225 M	MB20
MC 600M	MB25
SC 925 M	

Bolzenvorlagerung (Seitenkraft Aufnahme)

Serie	Bestell-Nr.
MC 10 M	BV8
MC 25 M	BV10
MC 75 M	BV12
MC 150 M	BV14
MC 225 M	BV20
MC 600M	BV25
SC 925 M	

Zubehör

Rechteck-Flansch

Serie	Bestell-Nr.
MC 9 M	RF6
MC 10 M	RF8
MC 25 M	RF10
MC 75 M	RF12
MC 150 M	RF14
MC 225 M	RF20
MC 600M	RF25
SC 925 M	



Sicherungsmutter

Serie	Bestell-Nr.
MC 9 M	KM6
MC 10 M	KM8
MC 25 M	KM10
MC 75 M	KM12
MC 150 M	KM14
MC 225 M	KM20
MC 600M	KM25
SC 925 M	



Baureihe MC 33 bis MC 64

Hub (mm)	Ø	Bestell-Nr.
25	M33 x 1,5	MC 3325 M-1
50	M33 x 1,5	MC 3350 M-1
25	M45 x 1,5	MC 4525 M-1
50	M45 x 1,5	MC 4550 M-1
75	M45 x 1,5	MC 4575 M-1
50	M64 x 2	MC 6450 M-1
100	M64 x 2	MC 64100 M-1
150	M64 x 2	MC 64150 M-1



Zubehör

Nutmutter

Serie	Bestell-Nr.
MC 33	NM33
MC 45	NM45
MC 64	NM64



PU-Kopf

Serie	Bestell-Nr.
MC 33	PP33
MC 45	PP45
MC 64	PP64



Quadrat-Flansch

Serie	Bestell-Nr.
MC 33	QF33
MC 45	QF45
MC 64	QF64



Seitliche Fußmontage



Serie	Bestell-Nr.
MC3325M & MC3350M	S33
MC4525M, MC4550M & MC4575M	S45
MC6450M, MC64100M & MC64150M	S64

Schwenk-Montagesatz



Serie	Bestell-Nr.
MC 33	C33
MC 45	C45
MC 64	C64

Gabelbefestigung



Serie	Bestell-Nr.
	P1C-4KMC
	P1C-4MMC
	P1C-4PMC

Abmessungen (mm)

Baureihe MC 9 M bis MC 75 M

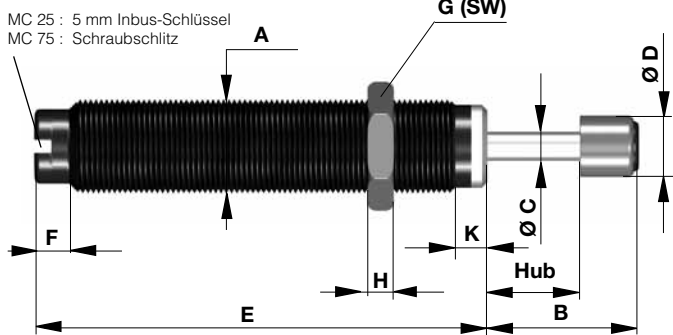

Baureihe MC 150 M bis MC 600 M

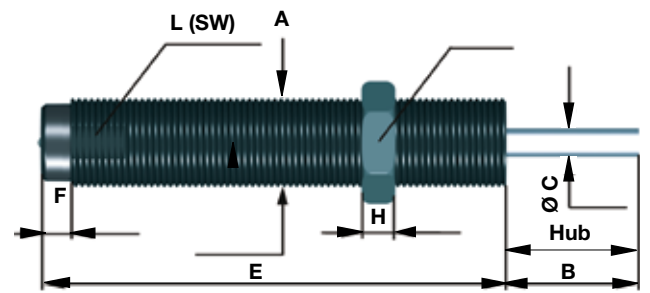

Bestell-Nr.	Hub (mm)	A	B	C	D	E	F	G	H	K	L
MC 9 M-1-B	5	M6 x 0,5	10	2	4,8	26	2,5	8	2,5	1	-
MC 9 M-2-B	5	M6 x 0,5	10	2	4,8	26	2,5	8	2,5	1	-
MC 10 ML-B	5	M8 x 1	10	2	6,4	28,5	5	11	3	2	-
MC 10 MH-B	5	M8 x 1	10	2	6,4	28,5	5	11	3	2	-
MC 25 ML	6,6	M10 x 1	14,6	3,2	7,6	43,4	5	13	3	5	-
MC 25 M	6,6	M10 x 1	14,6	3,2	7,6	43,4	5	13	3	5	-
MC 25 MH	6,6	M10 x 1	14,6	3,2	7,6	43,4	5	13	3	5	-
MC 75 M-1	10	M12 x 1	18	3,2	7,6	52	5	14	4	3	-
MC 75 M-2	10	M12 x 1	18	3,2	7,6	52	5	14	4	3	-
MC 75 M-3	10	M12 x 1	18	3,2	7,6	52	5	14	4	3	-
MC 150 M	12,5	M14 x 1,5	17,5	4,8	-	70	8,5	17	5	-	12
MC 150 MH	12,5	M14 x 1,5	17,5	4,8	-	70	8,5	17	5	-	12
MC 150 MH2	12,5	M14 x 1,5	17,5	4,8	-	70	8,5	17	5	-	12
MC 225 M	12,5	M20 x 1,5	17,5	6,3	-	80	8,5	24	6	-	18
MC 225 MH	12,5	M20 x 1,5	17,5	6,3	-	80	8,5	24	6	-	18
MC 225 MH2	12,5	M20 x 1,5	17,5	6,3	-	80	8,5	24	6	-	18
MC 600 M	25,4	M25 x 1,5	32	8	-	111	9	30	8	-	23
MC 600 MH	25,4	M25 x 1,5	32	8	-	111	9	30	8	-	23
MC 600 MH2	25,4	M25 x 1,5	32	8	-	111	9	30	8	-	23

Baureihe SC 925

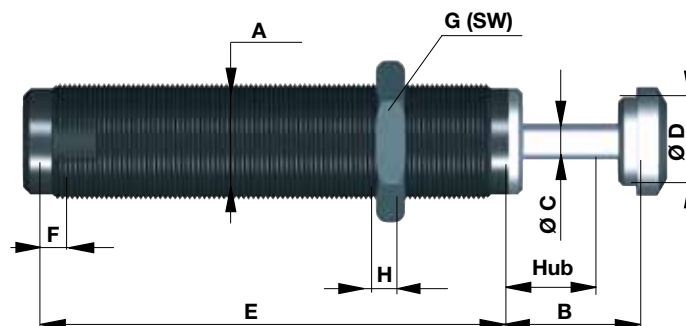

Bestell-Nr.	Hub (mm)	A	B	C	D	E	F	G	H
SC 925 M-1	40	M25 x 1,5	51	6,3	23	138	7	30	8
SC 925 M-2	40	M25 x 1,5	51	6,3	23	138	7	30	8
SC 925 M-3	40	M25 x 1,5	51	6,3	23	138	7	30	8

Abmessungen (mm)

Anschlaghülse

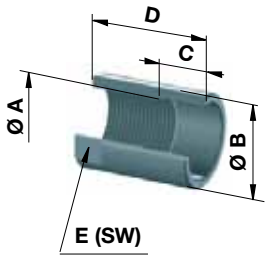

Bestell-Nr.	für Baureihe	ØA	ØB	C	D	E
AH6	MC 9 M	M 6 x 0,5	8	6	12	-
AH8	MC 10 M	M 8 x 1	11	6	12	-
AH10	MC 25 M	M 10 x 1	14	10	20	-
AH12	MC 75 M	M 12 x 1	16	10	20	-
AH14	MC 150 M	M 14 x 1,5	18	12	20	15
AH20	MC 225 M	M 20 x 1,5	25	12	25	22
AH25	MC 600 M	M 25 x 1,5	32	16	32	27
	SC 925 M	M 25 x 1,5	32	16	32	27

Klemmflansch

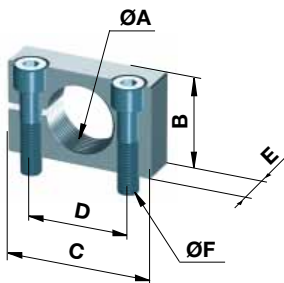

Bestell-Nr.	für Baureihe	ØA	B	C	D	E	ØF
MB6	MC 9 M	M 6 x 0,5	10	20	12	8	M3
MB8	MC 10 M	M 8 x 1	12	25	16	10	M4
MB10	MC 25 M	M 10 x 1	14	25	16	10	M4
MB12	MC 75 M	M 12 x 1	16	32	20	12	M5
MB14	MC 150 M	M 14 x 1,5	20	32	20	12	M5
MB20	MC 225 M	M 20 x 1,5	25	40	28	20	M6
MB25	MC 600 M	M 25 x 1,5	32	46	34	25	M6
	SC 925 M	M 25 x 1,5	32	46	34	25	M6

Bolzenvorlagerung

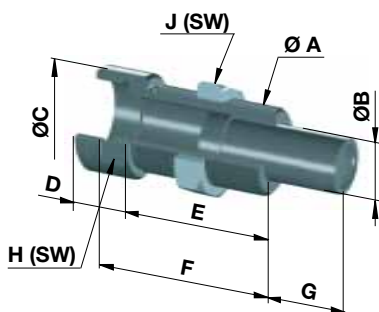

Bestell-Nr.	für Baureihe	ØA	ØB	ØC	D	E	ØF	G	H	J
BV8	MC 10 M	M 8 x 1	4	11	10	10	12	5	9	11
BV10	MC 25 M	M 10 x 1	6	13	11	12	15	6,5	11	13
BV12	MC 75 M	M 12 x 1	7	15	12	18	22	10	14	14
BV14	MC 150 M	M 14 x 1,5	9	18	12	20	24	12,5	16	17
BV20	MC 225 M	M 20 x 1,5	12	24	14	20	24	12,5	22	24
BV25	MC 600 M	M 25 x 1,5	16	30	16	38	44	25	27	30
	SC 925 M	M 25 x 1,5	16	30	16	38	44	25	27	30

Abmessungen (mm)

Rechteckflansch

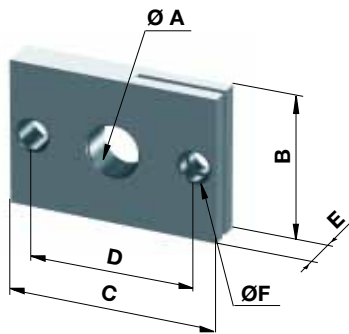

Bestell-Nr.	für Baureihe	ØA	B	C	D	E	ØF
RF6	MC 9 M	M 6 x 0,5	10	20	14	5	3,4
RF8	MC 10 M	M 8 x 1	14	25	18	6	4,5
RF10	MC 25 M	M 10 x 1	14	28	20	6	4,5
RF12	MC 75 M	M 12 x 1	20	32	24	6	5,5
RF14	MC 150 M	M 14 x 1,5	20	34	26	6	5,5
RF20	MC 225 M	M 20 x 1,5	32	46	36	8	6,5
RF25	MC 600 M	M 25 x 1,5	32	52	42	8	6,5
	SC 925 M	M 25 x 1,5	32	52	42	8	6,5

Sicherungsmutter

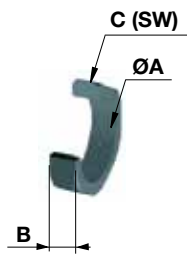

Bestell-Nr.	für Baureihe	A	B	C
KM6	MC 9 M	M 6 x 0,5	2,5	8
KM8	MC 10 M	M 8 x 1	3	11
KM10	MC 25 M	M 10 x 1	3	13
KM12	MC 75 M	M 12 x 1	4	14
KM14	MC 150 M	M 14 x 1,5	5	17
KM20	MC 225 M	M 20 x 1,5	6	24
KM25	MC 600 M	M 25 x 1,5	8	30
	SC 925 M	M 25 x 1,5	8	30

Abmessungen (mm)

Baureihe MC 33 bis MC 64

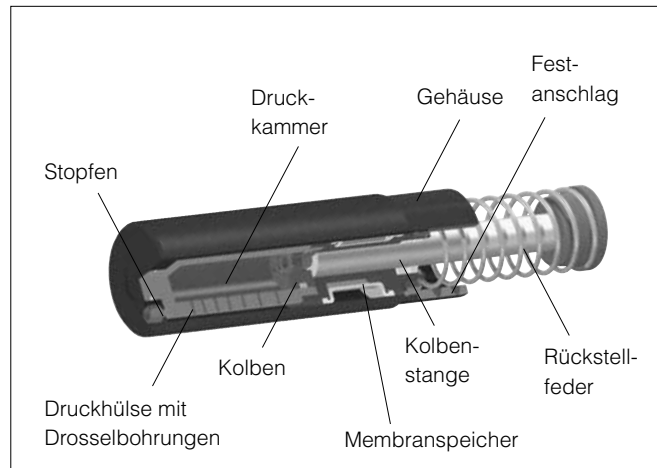

Baureihe	MC 3325 M	MC 3350 M	MC 4525 M	MC 4550 M	MC 4575 M	MC 6450 M	MC 64100 M	MC 64150 M
Gewinde (mm)	M33 x 1,5	M33 x 1,5	M45 x 1,5	M45 x 1,5	M45 x 1,5	M64 x 2	M64 x 2	M64 x 2
Ausführung	Selbsteinstellend							
Mechanischer Stopp	Festanschlag integriert							
Impact velocity (m/s)	0,15 bis 5							
Hub (mm)	25	50	25	20	75	50	100	150
Max. Kapazität pro Arbeitsspiel (Nm)	155	310	340	680	1020	1700	3400	5100
Temperatur (°C)	- 12 bis 70							

Abmessungen (mm)

Baureihe MC 33 bis MC 64

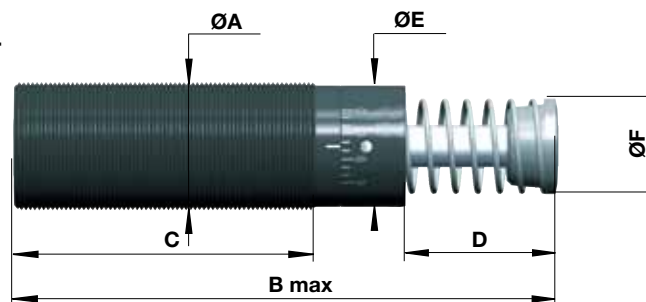

Bestell-Nr.	Hub (mm)	A	B	C	D	E	F
MC 3325 M	25	M33 x 1,5	138	83	23	30	25
MC 3350 M	50	M33 x 1,5	189	108	48,5	30	25
MC 4525 M	25	M45 x 1,5	145	95	23	42	35
MC 4550 M	50	M45 x 1,5	195	120	48,5	42	35
MC 4575 M	75	M45 x 1,5	246	145	74	42	35
MC 6450 M	50	M64 x 2	225	140	48,5	60	48
MC 64100 M	100	M64 x 2	326	191	99,5	60	48
MC 64150 M	150	M64 x 2	450	241	150	60	48

Abmessungen (mm)

Nutmutter

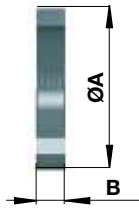

Bestell-Nr.	passend für Baureihen	ØA	B
NM33	MC 3325 M & MC 3350 M	40	6
NM45	MC 4525 M & MC 4550 M & MC 4575 M	57	10
NM64	MC 6450 M & MC 64100 M & MC 64150 M	76	10

PU-Kopf

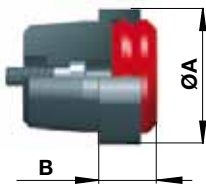

Bestell-Nr.	passend für Baureihen	ØA	B
PP33	MC 3325 M & MC 3350 M	29	12
PP45	MC 4525 M & MC 4550 M & MC 4575 M	42	18
PP64	MC 6450 M & MC 64100 M & MC 64150 M	60	18

Quadratflansch

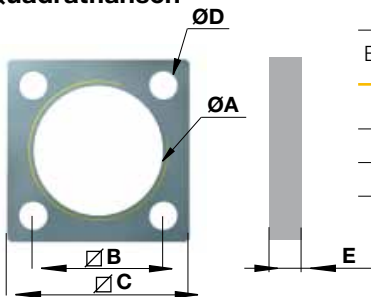

Bestell-Nr.	passend für Baureihen	ØA	ØD	∅B	∅C	E
QF33	MC 3325 M & MC 3350 M	M33 x 1,5	6,6	32	44	12
QF45	MC 4525 M & MC 4550 M & MC 4575 M	M45 x 1,5	9	42	56	15
QF64	MC 6450 M & MC 64100 M & MC 64150 M	M64 x 2	11	58	80	20

Fußbefestigung

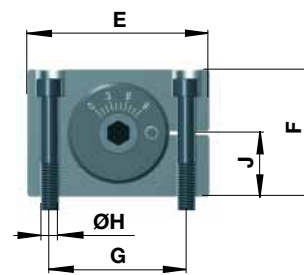
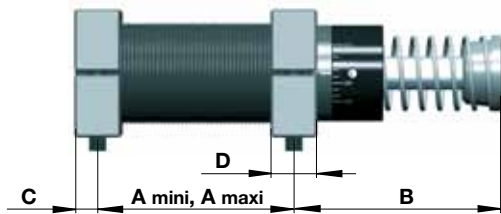

- S33** = 2 Flanschen + 4 Schrauben M6 x40
- S45** = 2 Flanschen + 4 Schrauben M8 x50
- S64** = 2 Flanschen + 4 Schrauben M10 x80

- Anzugsmoment**
S33 = 11 Nm **S45** = 27 Nm **S64** = 50 Nm
- Lösemoment**
S33 > 90 Nm **S45** > 350 Nm **S64** > 350 Nm

Bestell-Nr.	passend für Baureihen	A mini	A maxi	B	C	D	E	F	G	ØH	J
S33	MC 3325 M	25	60	68	10	20	56	40	42	6,6	20
S33	MC 3350 M	32	86	93	10	20	56	40	42	6,6	20
S45	MC 4525 M	32	66	66	12,5	25	80	56	60	9	28
S45	MC 4550 M	40	92	91	12,5	25	80	56	60	9	28
S45	MC 4575 M	50	118	116	12,5	25	80	56	60	9	28
S64	MC 6450 M	50	112	100	12,5 ²	25	100	80	78	11	40
S64	MC 64100 M	64	162	152	12,5	25	100	80	78	11	40
S64	MC 64150 M	80	212	226	12,5	25	100	80	78	11	40

Abmessungen (mm)

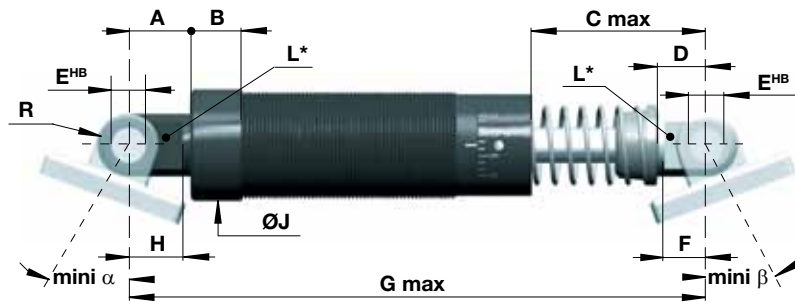

S33 =
S45 = Stoßdämpfer wird mit 2 Gelenkaugen montiert geliefert
S64 =

Bestell-Nr.	passend für Baureihen	A	B	Cmax	D	E ^{HB}	F	G max	H	ØJ	L*	R	mini α	mini β
C33	MC 3325 M	14	14	39	14	10	13	168	13	38	13	10	20°	0°
C33	MC 3350 M	14	14	64	14	10	13	218	13	38	13	10	20°	0°
C45	MC 4525 M	28	20	43	18	16	17	200	20	53	20	14	15°	15°
C45	MC 4550 M	28	20	68	18	13	17	250	20	53	20	14	15°	15°
C45	MC 4575 M	28	20	93	18	13	17	300	20	53	20	14	15°	15°
C64	MC 6450 M	35	25	85	35	20	30	310	30	74	24	20	20°	10°
C64	MC 64100 M	35	25	136	35	20	30	410	30	74	24	20	20°	10°
C64	MC 64150 M	35	25	187	35	20	30	530	30	74	24	20	20°	10°

L* gibt die Breite des vorderen und hinteren Gelenkauges an

Gabelbefestigung

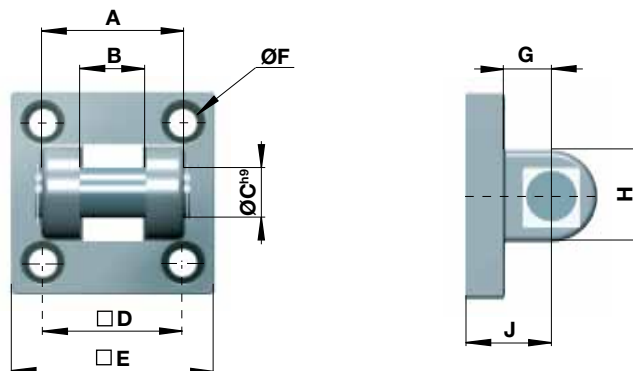

Ausgestattet mit 4 Montageschrauben

Bestell-Nr.	passend für Baureihen	A	B	ØC ^{HB}	□ D	□ E	Ø F	G	H	J
P1C-4KMC	MC 3325 M, MC 3350 M	34	14	10	32	48	7	13	23	22
P1C-4MMC	MC 4525 M, MC 4550 M, MC 4575 M	45	21	16	46	65	9	15	29	27
P1C-4PMC	MC 6450 M, MC 64100 M, MC 64150 M	65	25	20	72	95	11	22	45	36